

FF8,5HBK

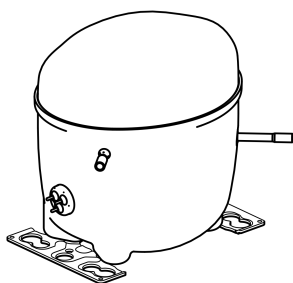

ENGINEERING CODE
513201031

REFRIGERANT
R-134a

POWER SUPPLY
220-240 V 50 Hz

APPLICATION
L/M/HBP

MOTOR TYPE
RSIR/CSIR

STANDARD
AHRI

COOLING CAPACITY
663 W

EFFICIENCY
1.97 W/W



DATA

GENERAL DATA

Model	FF8,5HBK
Type	Hermetic Reciprocating
Technology	ON/OFF
Compressor Application	L/M/HBP
Expansion Device	Capillary Tube
Compressor Cooling	Fan/220
HP	1/4
Starting Torque	LST
Plant	BRAZIL

ELECTRICAL DATA

Start Winding Resistance	24.0 Ω at 25°C
Run Winding Resistance	8.6 Ω at 25°C
Locked Rotor Amperage (LRA) 50Hz	18.2 A
Rated Load Amperage (LMBP) at 50 Hz	2 A
Rated Load Amperage (HBP) at 50 Hz	2.4 A

MECHANICAL DATA

Displacement	7.95 cm ³
Oil Charge	280 ml
Oil Type	ESTER
Oil Viscosity	ISO22
Weight	10.1 Kg

ELECTRICAL COMPONENTS

Start Capacitor	88-108 µf/180 V
CSR CSIR BOX	No
Starting Device Type	RELAY
Starting Device Description	213516442 213516469*
Overload Protection	MRP61AMZ-5590

PERFORMANCE

TESTED CONDITIONS

Tested Refrigerant	R-134a
Tested Application	HBP
Tested Standard	AHRI
Tested Cooling	Fan
Tested Voltage	220 V
Max Refrigerant Charge	250 g
Refrigerant Temperature	Dew

RATED POINTS

Condensing Temperature °C	Evaporating Temperature °C	Cooling Capacity W	Efficiency W/W	Power Consumption W	Current A	Gas Flow Rate kg/h
54.4	7.2	663	1.97	336	-	17.81

Test Condition: Subcooling 0 K, Return Gas 18.3 °C. Data are an indication of performance based simulation.

PERFORMANCE CURVE

Condensing Temperature 45°C

Evaporating Temperature °C	Cooling Capacity W	Efficiency W/W	Power Consumption W	Current A	Gas Flow Rate kg/h
-35	86	0.70	123	-	1.98
-30	120	0.86	141	-	2.81
-25	165	1.02	161	-	3.85
-20	221	1.20	184	-	5.15
-15	288	1.39	207	-	6.73
-10	369	1.60	230	-	8.66
-5	464	1.85	251	-	10.96
0	574	2.13	270	-	13.68
5	700	2.46	285	-	16.86
10	844	2.86	295	-	20.55
15	1005	3.37	298	-	24.79

Test Condition: Subcooling 0 K, Return Gas 18.3 °C. Data are an indication of performance based simulation.

PERFORMANCE CURVE

Condensing Temperature 55°C

Evaporating Temperature °C	Cooling Capacity W	Efficiency W/W	Power Consumption W	Current A	Gas Flow Rate kg/h
-30	95	0.68	140	-	2.47
-25	134	0.82	163	-	3.48
-20	183	0.96	189	-	4.73
-15	241	1.11	217	-	6.27
-10	312	1.26	247	-	8.16
-5	395	1.43	276	-	10.41
0	492	1.62	303	-	13.09
5	603	1.83	329	-	16.23
10	730	2.08	350	-	19.87
15	874	2.38	367	-	24.06

Test Condition: Subcooling 0 K, Return Gas 18.3 °C. Data are an indication of performance based simulation.

PERFORMANCE CURVE

Condensing Temperature 65°C

Evaporating Temperature °C	Cooling Capacity W	Efficiency W/W	Power Consumption W	Current A	Gas Flow Rate kg/h
-25	103	0.66	157	-	3.02
-20	144	0.77	186	-	4.23
-15	194	0.89	219	-	5.72
-10	254	1.00	253	-	7.55
-5	325	1.12	289	-	9.76
0	408	1.26	325	-	12.38
5	504	1.40	360	-	15.47
10	615	1.57	392	-	19.05
15	741	1.76	422	-	23.19

Test Condition: Subcooling 0 K, Return Gas 18.3 °C. Data are an indication of performance based simulation.

ENVELOPE

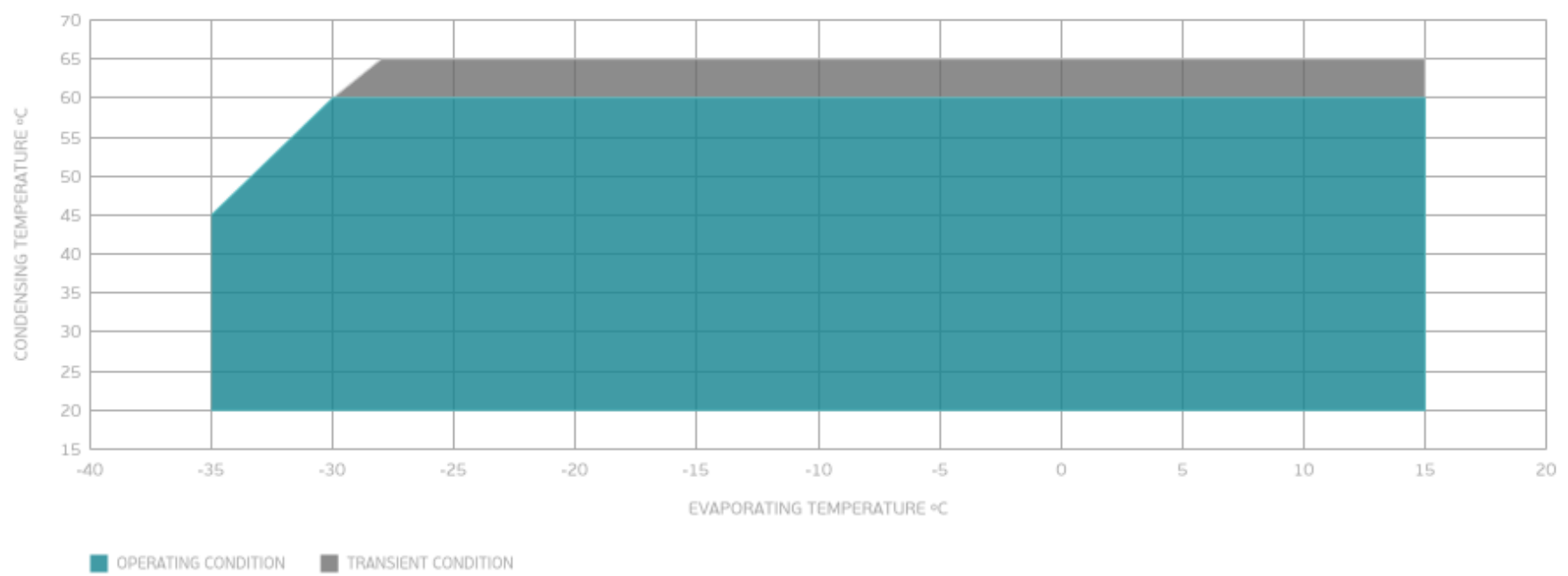

External

EXTERNAL CHARACTERISTICS

Base Plate		UNI V2	
Tray Holder		NO	
Connector	Internal Diameter	Shape	Material
Suction	8.2 mm	SLANTED	COPPER
Discharge	6.5 mm	SLANTED	COPPER
Process	6.5 mm	SLANTED	COPPER

EXTERNAL DIMENSIONS

SHELL

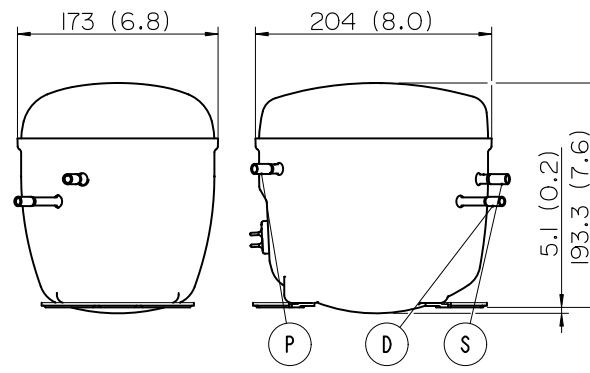

BASE

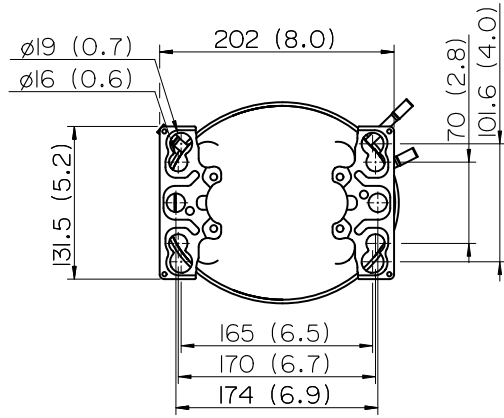

FENCE

