

FFI10HAK

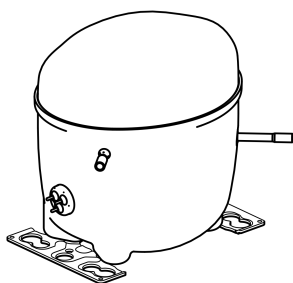

ENGINEERING CODE
513200647

REFRIGERANT
R-134a

POWER SUPPLY
220-230 V 50-60 Hz

APPLICATION
L/MBP

MOTOR TYPE
RSIR/CSIR

STANDARD
ASHRAE

COOLING CAPACITY
527 W

EFFICIENCY
1.84 W/W

DATA

GENERAL DATA

Model	FFI10HAK
Type	Hermetic Reciprocating
Technology	ON/OFF
Compressor Application	L/MBP
Expansion Device	Capillary Tube
Compressor Cooling	Static/220
HP	1/3
Starting Torque	LST
Plant	BRAZIL

ELECTRICAL DATA

Start Winding Resistance	28.15 Ω at 25°C
Run Winding Resistance	7.15 Ω at 25°C
Locked Rotor Amperage (LRA) 50Hz	18 A
Locked Rotor Amperage (LRA) 60Hz	17.5 A
Rated Load Amperage (LMBP) at 50 Hz	2.5 A
Rated Load Amperage (LMBP) at 60 Hz	2.2 A

MECHANICAL DATA

Displacement	9.04 cm ³
Oil Charge	280 ml
Oil Type	ESTER
Oil Viscosity	ISO22
Weight	11.4 Kg

ELECTRICAL COMPONENTS

Start Capacitor	53-64 µf/230 V
CSR CSIR BOX	No
Starting Device Type	RELAY
Starting Device Description	213516035 213516043*
Overload Protection	4TM757KFBYY-53 CP4TMF210L61A2 DRB210L61A*F

PERFORMANCE

TESTED CONDITIONS

Tested Refrigerant	R-134a
Tested Application	MBP
Tested Standard	ASHRAE
Tested Cooling	Static
Tested Voltage	220 V
Max Refrigerant Charge	250 g
Refrigerant Temperature	Dew

Performance on Compressor Speed: 3000 RPM

RATED POINTS

Condensing Temperature °C	Evaporating Temperature °C	Cooling Capacity W	Efficiency W/W	Power Consumption W	Current A	Gas Flow Rate kg/h
54.4	-6.7	527	1.84	286	-	11.47

Test Condition: Subcooling 8.3 K, Return Gas 35 °C. Data are an indication of performance based simulation.

PERFORMANCE CURVE

Condensing Temperature 45°C

Evaporating Temperature °C	Cooling Capacity W	Efficiency W/W	Power Consumption W	Current A	Gas Flow Rate kg/h
-35	121	0.90	135	-	2.40
-30	171	1.10	155	-	3.39
-25	236	1.33	177	-	4.68
-20	317	1.58	200	-	6.30
-15	413	1.85	224	-	8.24
-10	526	2.13	247	-	10.52
-5	655	2.44	268	-	13.16

Test Condition: Subcooling 8.3 K, Return Gas 35 °C. Data are an indication of performance based simulation.

PERFORMANCE CURVE

Condensing Temperature 55°C

Evaporating Temperature °C	Cooling Capacity W	Efficiency W/W	Power Consumption W	Current A	Gas Flow Rate kg/h
-30	138	0.89	155	-	2.99
-25	195	1.08	181	-	4.22
-20	266	1.27	209	-	5.76
-15	350	1.47	238	-	7.62
-10	449	1.67	268	-	9.80
-5	562	1.89	297	-	12.31

Test Condition: Subcooling 8.3 K, Return Gas 35 °C. Data are an indication of performance based simulation.

PERFORMANCE CURVE

Condensing Temperature 65°C

Evaporating Temperature °C	Cooling Capacity W	Efficiency W/W	Power Consumption W	Current A	Gas Flow Rate kg/h
-25	151	0.86	176	-	3.60
-20	212	1.02	209	-	5.06
-15	285	1.17	243	-	6.83
-10	370	1.32	280	-	8.91
-5	467	1.48	317	-	11.31

Test Condition: Subcooling 8.3 K, Return Gas 35 °C. Data are an indication of performance based simulation.

Performance on Compressor Speed: 3600 RPM

RATED POINTS

Condensing Temperature °C	Evaporating Temperature °C	Cooling Capacity W	Efficiency W/W	Power Consumption W	Current A	Gas Flow Rate kg/h
54.4	-6.7	620	1.85	336	-	13.52

Test Condition: Subcooling 8.3 K, Return Gas 35 °C. Data are an indication of performance based simulation.

PERFORMANCE CURVE

Condensing Temperature 45°C

Evaporating Temperature °C	Cooling Capacity W	Efficiency W/W	Power Consumption W	Current A	Gas Flow Rate kg/h
-35	144	1.04	139	-	2.85
-30	217	1.29	169	-	4.30
-25	299	1.51	198	-	5.93
-20	392	1.72	228	-	7.79
-15	496	1.93	257	-	9.89
-10	613	2.14	287	-	12.26
-5	743	2.36	315	-	14.93

Test Condition: Subcooling 8.3 K, Return Gas 35 °C. Data are an indication of performance based simulation.

PERFORMANCE CURVE

Condensing Temperature 55°C

Evaporating Temperature °C	Cooling Capacity W	Efficiency W/W	Power Consumption W	Current A	Gas Flow Rate kg/h
-30	163	1.01	161	-	3.52
-25	237	1.21	196	-	5.12
-20	323	1.39	233	-	7.00
-15	422	1.56	271	-	9.16
-10	534	1.72	310	-	11.65
-5	660	1.88	352	-	14.49

Test Condition: Subcooling 8.3 K, Return Gas 35 °C. Data are an indication of performance based simulation.

PERFORMANCE CURVE

Condensing Temperature 65°C

Evaporating Temperature °C	Cooling Capacity W	Efficiency W/W	Power Consumption W	Current A	Gas Flow Rate kg/h
-25	186	0.97	191	-	4.43
-20	262	1.13	232	-	6.26
-15	352	1.27	277	-	8.44
-10	456	1.41	324	-	10.98
-5	576	1.54	374	-	13.93

Test Condition: Subcooling 8.3 K, Return Gas 35 °C. Data are an indication of performance based simulation.

ENVELOPE

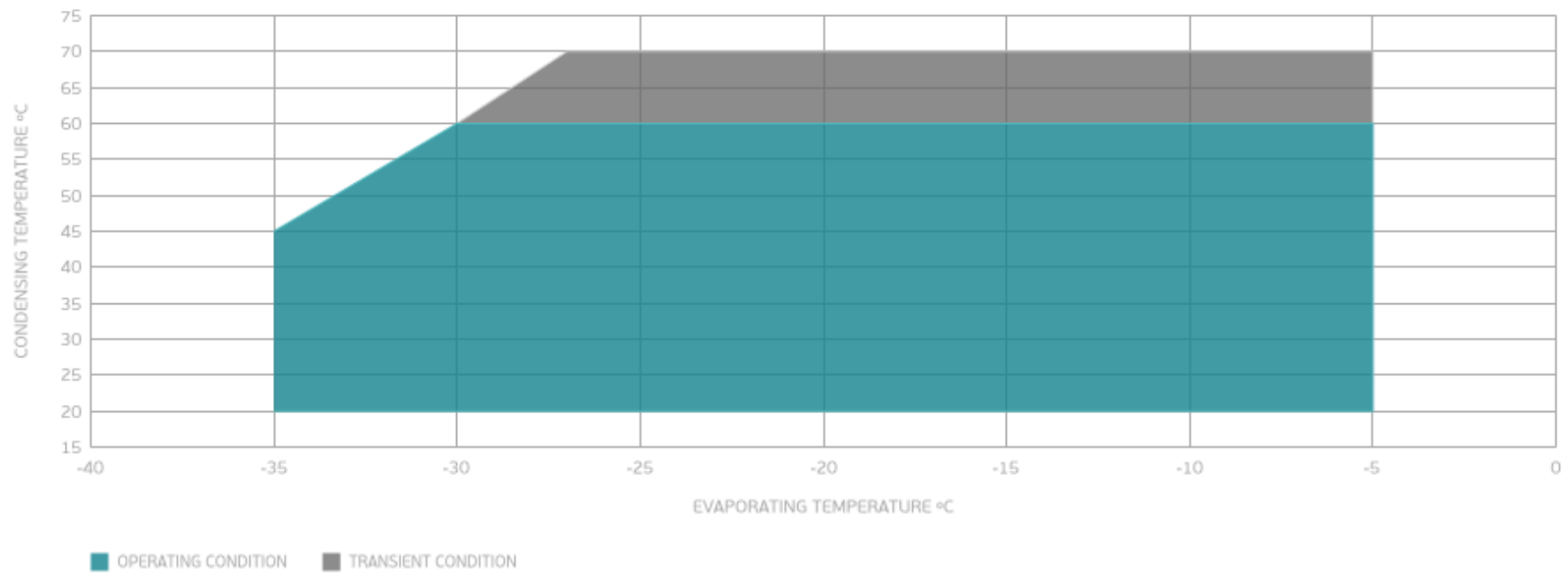

External

EXTERNAL CHARACTERISTICS

Base Plate UNI V2

Tray Holder NO

Connector	Internal Diameter	Shape	Material
Suction	8.2 mm	SLANTED	COPPER PLATED STEEL
Discharge	6.5 mm	SLANTED	COPPER PLATED STEEL
Process	6.5 mm	SLANTED	COPPER PLATED STEEL

EXTERNAL DIMENSIONS

SHELL

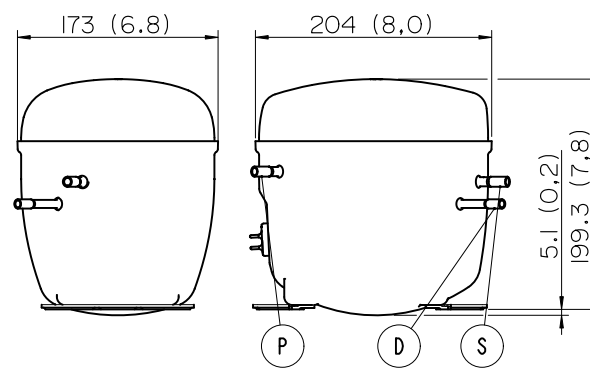

BASE

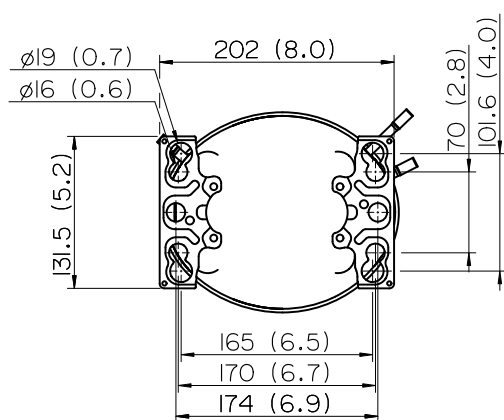

FENCE

