

FFI12HBK

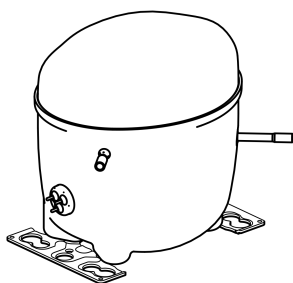

ENGINEERING CODE
513200381

REFRIGERANT
R-134a

POWER SUPPLY
220-240 V 50 Hz

APPLICATION
L/M/HBP

MOTOR TYPE
RSIR/CSIR

STANDARD
ASHRAE

COOLING CAPACITY
661 W

EFFICIENCY
1.69 W/W

DATA

GENERAL DATA

Model	FFI12HBK
Type	Hermetic Reciprocating
Technology	ON/OFF
Compressor Application	L/M/HBP
Expansion Device	Capillary Tube
Compressor Cooling	Fan/220
HP	1/3+
Starting Torque	LST
Plant	BRAZIL

ELECTRICAL DATA

Start Winding Resistance	29.9 Ω at 25°C
Run Winding Resistance	5.7 Ω at 25°C
Locked Rotor Amperage (LRA) 50Hz	20 A
Rated Load Amperage (LMBP) at 50 Hz	2.5 A
Rated Load Amperage (HBP) at 50 Hz	3 A

MECHANICAL DATA

Displacement	11.14 cm ³
Oil Charge	280 ml
Oil Type	ESTER
Oil Viscosity	ISO22
Weight	11.4 Kg

ELECTRICAL COMPONENTS

Start Capacitor	88-108 µf/220 V
CSR CSIR BOX	No
Starting Device Type	RELAY
Starting Device Description	213516035 213516043*
Overload Protection	4TM757KFBYY-53 5TM 757KFBYY-53 CP4TMF210N52A2 DRB210N52A*F MRP40APN-5590 MRP40APN-5598

PERFORMANCE

TESTED CONDITIONS

Tested Refrigerant	R-134a
Tested Application	MBP
Tested Standard	ASHRAE
Tested Cooling	Fan
Tested Voltage	220 V
Max Refrigerant Charge	250 g
Refrigerant Temperature	Dew

RATED POINTS

Condensing Temperature °C	Evaporating Temperature °C	Cooling Capacity W	Efficiency W/W	Power Consumption W	Current A	Gas Flow Rate kg/h
54.4	-6.7	661	1.69	391	-	14.39

Test Condition: Subcooling 8.3 K, Return Gas 35 °C. Data are an indication of performance based simulation.

PERFORMANCE CURVE

Condensing Temperature 45°C

Evaporating Temperature °C	Cooling Capacity W	Efficiency W/W	Power Consumption W	Current A	Gas Flow Rate kg/h
-35	158	0.84	187	-	3.11
-30	218	1.03	212	-	4.33
-25	297	1.23	241	-	5.90
-20	394	1.45	273	-	7.84
-15	511	1.67	305	-	10.17
-10	646	1.91	338	-	12.91
-5	801	2.17	369	-	16.08
0	976	2.45	398	-	19.70
5	1171	2.77	423	-	23.79
10	1386	3.13	443	-	28.36
15	1622	3.55	456	-	33.44

Test Condition: Subcooling 8.3 K, Return Gas 35 °C. Data are an indication of performance based simulation.

PERFORMANCE CURVE

Condensing Temperature 55°C

Evaporating Temperature °C	Cooling Capacity W	Efficiency W/W	Power Consumption W	Current A	Gas Flow Rate kg/h
-30	183	0.86	213	-	3.95
-25	254	1.03	246	-	5.49
-20	341	1.21	283	-	7.38
-15	445	1.38	323	-	9.66
-10	566	1.55	365	-	12.35
-5	705	1.73	407	-	15.45
0	861	1.92	449	-	18.99
5	1036	2.11	490	-	23.00
10	1229	2.33	527	-	27.48
15	1440	2.57	560	-	32.46

Test Condition: Subcooling 8.3 K, Return Gas 35 °C. Data are an indication of performance based simulation.

PERFORMANCE CURVE

Condensing Temperature 65°C

Evaporating Temperature °C	Cooling Capacity W	Efficiency W/W	Power Consumption W	Current A	Gas Flow Rate kg/h
-25	207	0.87	240	-	4.94
-20	285	1.01	281	-	6.80
-15	377	1.15	327	-	9.03
-10	484	1.28	377	-	11.65
-5	606	1.41	430	-	14.69
0	745	1.54	484	-	18.16
5	899	1.67	539	-	22.08
10	1069	1.81	592	-	26.47
15	1257	1.95	643	-	31.35

Test Condition: Subcooling 8.3 K, Return Gas 35 °C. Data are an indication of performance based simulation.

ENVELOPE

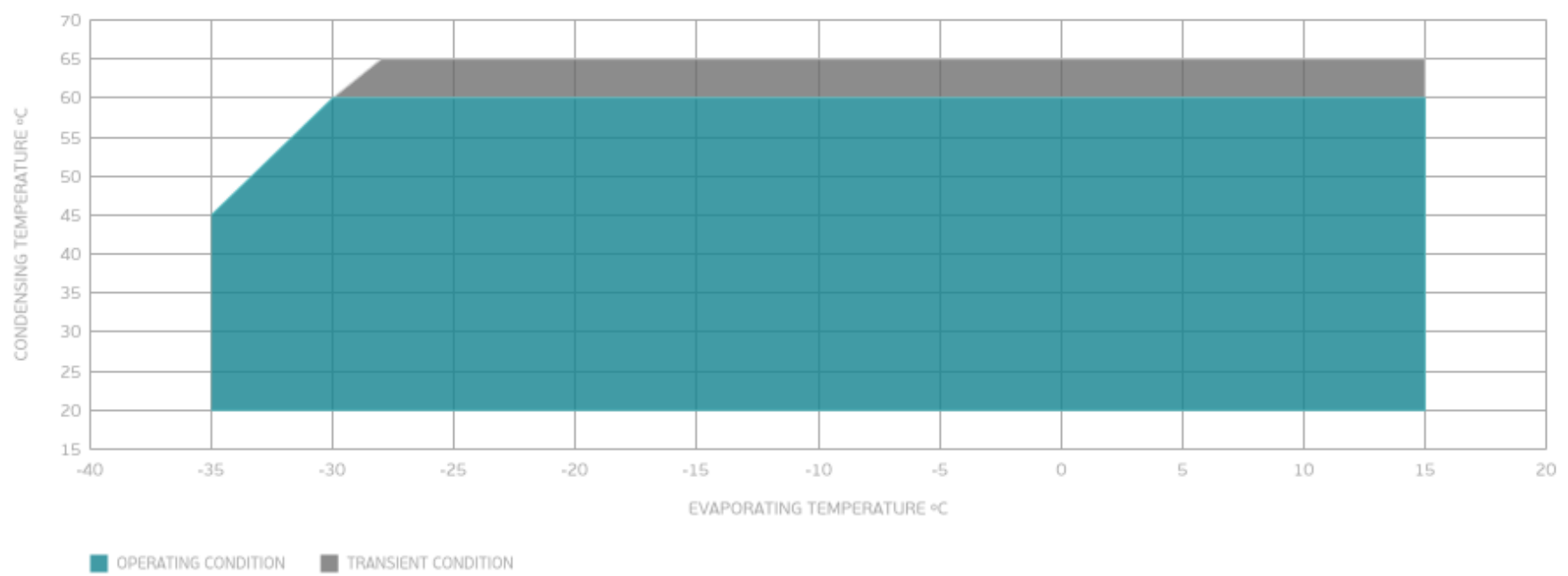

External

EXTERNAL CHARACTERISTICS

Base Plate		UNI V2	
Tray Holder		NO	
Connector	Internal Diameter	Shape	Material
Suction	6.5 mm	STRAIGHT	COPPER
Discharge	6.5 mm	STRAIGHT	COPPER
Process	6.5 mm	STRAIGHT	COPPER

EXTERNAL DIMENSIONS

SHELL

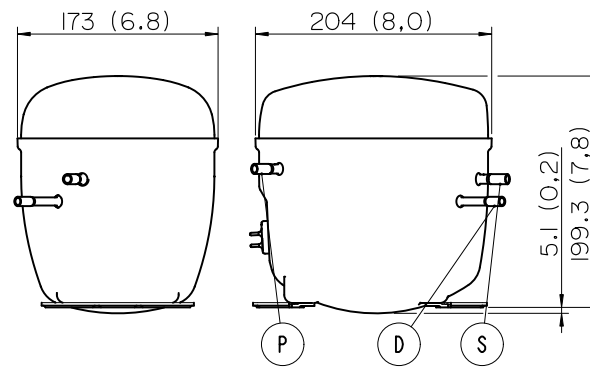

BASE

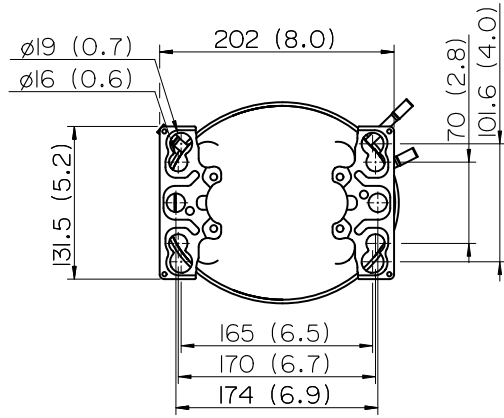

FENCE

