

NEU2140U



ENGINEERING CODE
862IA51



REFRIGERANT
R-290



POWER SUPPLY
220-240 V 50 Hz



APPLICATION
LBP



MOTOR TYPE
CSIR



STANDARD
ASHRAE



COOLING CAPACITY
488 W



EFFICIENCY
1.5 W/W



DATA

GENERAL DATA

Model	NEU2140U
Type	Hermetic Reciprocating
Technology	ON/OFF
Compressor Application	LBP
Expansion Device	Capillary Tube or Expansion Valve
Compressor Cooling	Fan/220
HP	1/2
Starting Torque	HST
Plant	SLOVAKIA

ELECTRICAL DATA

Start Winding Resistance	24.26 Ω at 25°C
Run Winding Resistance	7.79 Ω at 25°C
Locked Rotor Amperage (LRA) 50Hz	14 A

MECHANICAL DATA

Displacement	9.99 cm ³
Oil Charge	350 ml
Oil Type	AB
Oil Viscosity	ISO32
Weight	10.6 Kg

ELECTRICAL COMPONENTS

Start Capacitor	64-77 µf/330 V
CSR CSIR BOX	No
Starting Device Type	RELAY
Starting Device Description	MTRPH-0025-65*
Overload Protection	T0660/G6

PERFORMANCE

TESTED CONDITIONS

Tested Refrigerant	R-290
Tested Application	LBP
Tested Standard	ASHRAE
Tested Cooling	Fan
Tested Voltage	220 V
Refrigerant Temperature	Dew

RATED POINTS

Condensing Temperature °C	Evaporating Temperature °C	Cooling Capacity W	Efficiency W/W	Power Consumption W	Current A	Gas Flow Rate kg/h
54.4	-23.3	488	1.5	325	1.94	4.95

Test Condition: Liquid 32.2 °C, Return Gas 32.2 °C. Data generated in accordance to EN 12900:2013 polynomial equation and tolerance guidelines.

PERFORMANCE CURVE

Condensing Temperature 35°C

Evaporating Temperature °C	Cooling Capacity W	Efficiency W/W	Power Consumption W	Current A	Gas Flow Rate kg/h
-40	238	1.22	195	1.51	2.40
-35	308	1.40	220	1.59	3.11
-30	395	1.60	247	1.67	4.00
-25	499	1.83	273	1.75	5.06
-20	620	2.09	297	1.83	6.32
-15	759	2.37	320	1.92	7.76
-10	915	2.70	339	2.01	9.40

Test Condition: Liquid 32.2 °C, Return Gas 32.2 °C. Data generated in accordance to EN 12900:2013 polynomial equation and tolerance guidelines.

PERFORMANCE CURVE

Condensing Temperature 45°C

Evaporating Temperature °C	Cooling Capacity W	Efficiency W/W	Power Consumption W	Current A	Gas Flow Rate kg/h
-40	227	1.12	203	1.54	2.29
-35	294	1.26	233	1.63	2.97
-30	377	1.43	264	1.73	3.81
-25	477	1.61	296	1.83	4.84
-20	594	1.81	329	1.95	6.04
-15	728	2.02	361	2.07	7.44
-10	879	2.25	391	2.20	9.03

Test Condition: Liquid 32.2 °C, Return Gas 32.2 °C. Data generated in accordance to EN 12900:2013 polynomial equation and tolerance guidelines.

PERFORMANCE CURVE

Condensing Temperature 55°C

Evaporating Temperature °C	Cooling Capacity W	Efficiency W/W	Power Consumption W	Current A	Gas Flow Rate kg/h
-30	354	1.29	275	1.77	3.58
-25	450	1.44	313	1.90	4.56
-20	562	1.60	352	2.04	5.72
-15	691	1.76	392	2.19	7.06
-10	837	1.94	432	2.36	8.59

Test Condition: Liquid 32.2 °C, Return Gas 32.2 °C. Data generated in accordance to EN 12900:2013 polynomial equation and tolerance guidelines.

ENVELOPE



External

EXTERNAL CHARACTERISTICS

Base Plate		SMALL	
Tray Holder		NO	
Connector	Internal Diameter	Shape	Material
Suction	8.1 mm	SLANTED 42°	COPPER
Discharge	6.1 mm	STRAIGHT	COPPER

EXTERNAL DIMENSIONS

SHELL

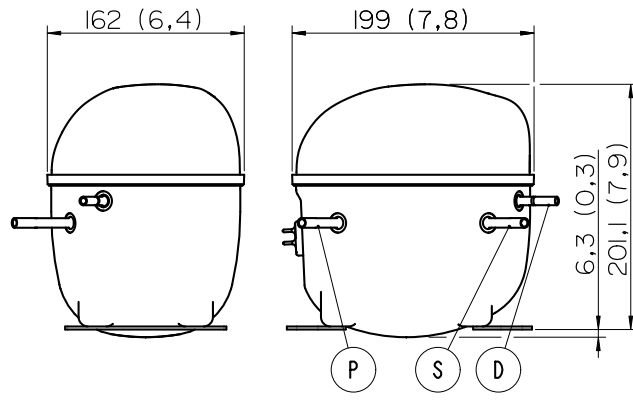

BASE



FENCE

