

NEU2155GK



**ENGINEERING CODE**  
954FA51

**REFRIGERANT**  
R-404A

**POWER SUPPLY**  
220-240 V 50 Hz

**APPLICATION**  
LBP

**MOTOR TYPE**  
CSIR

**STANDARD**  
ASHRAE

**COOLING CAPACITY**  
654 W

**EFFICIENCY**  
1.32 W/W



DATA

GENERAL DATA

Model	NEU2155GK
Type	Hermetic Reciprocating
Technology	ON/OFF
Compressor Application	LBP
Expansion Device	Capillary Tube or Expansion Valve
Compressor Cooling	Fan/220
HP	3/4
Starting Torque	HST
Plant	SLOVAKIA

ELECTRICAL DATA

Start Winding Resistance	17.09 Ω at 25°C
Run Winding Resistance	5.36 Ω at 25°C
Locked Rotor Amperage (LRA) 50Hz	19.5 A

## MECHANICAL DATA

Displacement	12.11 cm <sup>3</sup>
Oil Charge	350 ml
Oil Type	ESTER
Oil Viscosity	ISO22
Weight	10.7 Kg

## ELECTRICAL COMPONENTS

Start Capacitor	64-77 µf/330 V
CSR CSIR BOX	No
Starting Device Type	RELAY
Starting Device Description	MTRP-49*
Overload Protection	MSP30APK-3259

## PERFORMANCE

### TESTED CONDITIONS

Tested Refrigerant	R-404A
Tested Application	LBP
Tested Standard	ASHRAE
Tested Cooling	Fan
Tested Voltage	220 V
Refrigerant Temperature	Dew

### RATED POINTS

Condensing Temperature °C	Evaporating Temperature °C	Cooling Capacity W	Efficiency W/W	Power Consumption W	Current A	Gas Flow Rate kg/h
54.4	-23.3	654	1.32	497	3.06	15.14

Test Condition: Liquid 32.2 °C, Return Gas 32.2 °C. Data generated in accordance to EN 12900:2013 polynomial equation and tolerance guidelines.

### PERFORMANCE CURVE

Condensing Temperature 35°C

Evaporating Temperature °C	Cooling Capacity W	Efficiency W/W	Power Consumption W	Current A	Gas Flow Rate kg/h
-40	310	1.07	289	2.51	7.11
-35	410	1.24	332	2.59	9.44
-30	535	1.42	377	2.69	12.34
-25	684	1.62	423	2.82	15.86
-20	860	1.83	470	2.97	20.05
-15	1064	2.07	515	3.13	24.95
-10	1297	2.33	558	3.32	30.62

Test Condition: Liquid 32.2 °C, Return Gas 32.2 °C. Data generated in accordance to EN 12900:2013 polynomial equation and tolerance guidelines.

## PERFORMANCE CURVE

Condensing Temperature 45°C

Evaporating Temperature °C	Cooling Capacity W	Efficiency W/W	Power Consumption W	Current A	Gas Flow Rate kg/h
-40	285	0.96	297	2.52	6.53
-35	382	1.11	345	2.62	8.77
-30	502	1.26	398	2.75	11.56
-25	646	1.42	455	2.90	14.96
-20	817	1.59	515	3.09	19.00
-15	1015	1.76	576	3.30	23.75
-10	1241	1.95	637	3.54	29.24

Test Condition: Liquid 32.2 °C, Return Gas 32.2 °C. Data generated in accordance to EN 12900:2013 polynomial equation and tolerance guidelines.

## PERFORMANCE CURVE

Condensing Temperature 55°C

Evaporating Temperature °C	Cooling Capacity W	Efficiency W/W	Power Consumption W	Current A	Gas Flow Rate kg/h
-30	458	1.12	408	2.79	10.54
-25	598	1.26	474	2.99	13.80
-20	763	1.40	545	3.22	17.70
-15	954	1.54	621	3.49	22.28
-10	1173	1.68	699	3.79	27.58

Test Condition: Liquid 32.2 °C, Return Gas 32.2 °C. Data generated in accordance to EN 12900:2013 polynomial equation and tolerance guidelines.

## ENVELOPE

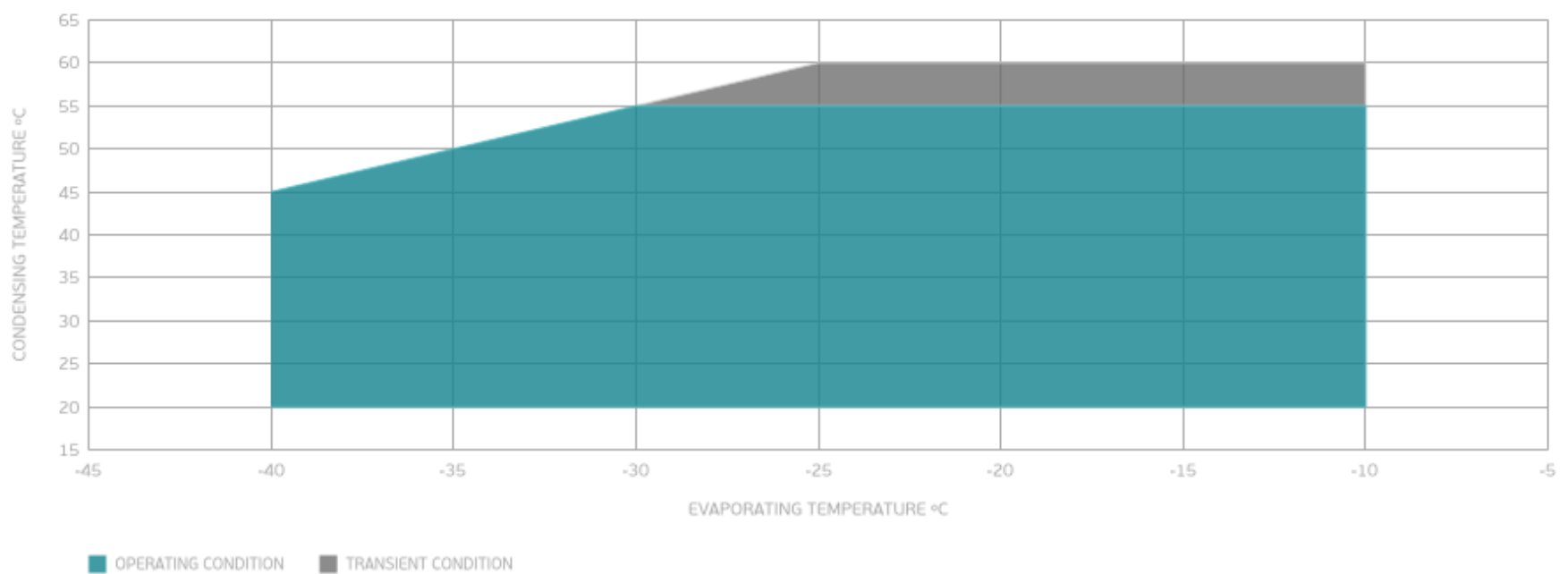

## External

### EXTERNAL CHARACTERISTICS

Base Plate		SMALL	
Tray Holder		NO	
<b>Connector</b>	<b>Internal Diameter</b>	<b>Shape</b>	<b>Material</b>
Suction	8.1 mm	SLANTED 42°	COPPER
Discharge	6.1 mm	STRAIGHT	COPPER

**EXTERNAL DIMENSIONS**

**SHELL**

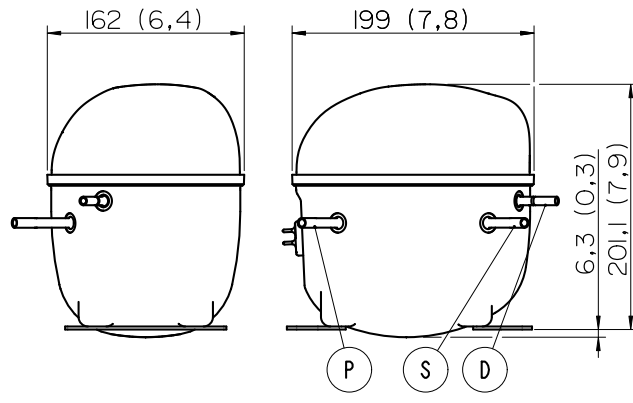

**BASE**



**FENCE**

