

NEU6212U



ENGINEERING CODE
862HA51



REFRIGERANT
R-290



POWER SUPPLY
220-240 V 50 Hz



APPLICATION
MBP



MOTOR TYPE
CSIR



STANDARD
ASHRAE



COOLING CAPACITY
846 W



EFFICIENCY
1.9 W/W



DATA

GENERAL DATA

Model	NEU6212U
Type	Hermetic Reciprocating
Technology	ON/OFF
Compressor Application	MBP
Expansion Device	Capillary Tube or Expansion Valve
Compressor Cooling	Fan/220
HP	1/2
Starting Torque	HST
Plant	SLOVAKIA

ELECTRICAL DATA

Start Winding Resistance	27.92 Ω at 25°C
Run Winding Resistance	4.53 Ω at 25°C
Locked Rotor Amperage (LRA) 50Hz	20.5 A
Rated Load Amperage (LMBP) at 50 Hz	2.8 A

MECHANICAL DATA

Displacement	9.99 cm ³
Oil Charge	350 ml
Oil Type	AB
Oil Viscosity	ISO32
Weight	11.2 Kg

ELECTRICAL COMPONENTS

Start Capacitor	53-64 µf/330 V
CSR CSIR BOX	No
Starting Device Type	RELAY
Starting Device Description	MTRP-0012*
Overload Protection	4TM758PFB

PERFORMANCE

TESTED CONDITIONS

Tested Refrigerant	R-290
Tested Application	MBP
Tested Standard	ASHRAE
Tested Cooling	Fan
Tested Voltage	220 V
Refrigerant Temperature	Dew

RATED POINTS

Condensing Temperature °C	Evaporating Temperature °C	Cooling Capacity W	Efficiency W/W	Power Consumption W	Current A	Gas Flow Rate kg/h
54.4	-6.7	846	1.9	446	3.24	9.68

Test Condition: Subcooling 8.3 K, Return Gas 35 °C. Data generated in accordance to EN 12900:2013 polynomial equation and tolerance guidelines.

PERFORMANCE CURVE

Condensing Temperature 35°C

Evaporating Temperature °C	Cooling Capacity W	Efficiency W/W	Power Consumption W	Current A	Gas Flow Rate kg/h
-20	642	1.98	325	2.92	6.18
-15	796	2.31	345	2.95	7.69
-10	971	2.65	366	3.00	9.43
-5	1171	3.04	385	3.05	11.41
0	1395	3.50	399	3.12	13.68
5	1646	4.08	404	3.20	16.24
10	1924	4.86	396	3.28	19.14

Test Condition: Subcooling 8.3 K, Return Gas 35 °C. Data generated in accordance to EN 12900:2013 polynomial equation and tolerance guidelines.

PERFORMANCE CURVE

Condensing Temperature 45°C

Evaporating Temperature °C	Cooling Capacity W	Efficiency W/W	Power Consumption W	Current A	Gas Flow Rate kg/h
-20	553	1.55	356	2.99	5.76
-15	691	1.83	378	3.04	7.22
-10	850	2.10	405	3.10	8.92
-5	1031	2.38	433	3.17	10.88
0	1237	2.69	459	3.24	13.12
5	1467	3.06	480	3.32	15.68
10	1725	3.51	491	3.41	18.58

Test Condition: Subcooling 8.3 K, Return Gas 35 °C. Data generated in accordance to EN 12900:2013 polynomial equation and tolerance guidelines.

PERFORMANCE CURVE

Condensing Temperature 55°C

Evaporating Temperature °C	Cooling Capacity W	Efficiency W/W	Power Consumption W	Current A	Gas Flow Rate kg/h
-10	734	1.73	425	3.19	8.41
-5	896	1.95	459	3.28	10.33
0	1081	2.19	494	3.38	12.54
5	1289	2.44	527	3.48	15.08
10	1523	2.75	555	3.59	17.96

Test Condition: Subcooling 8.3 K, Return Gas 35 °C. Data generated in accordance to EN 12900:2013 polynomial equation and tolerance guidelines.

ENVELOPE

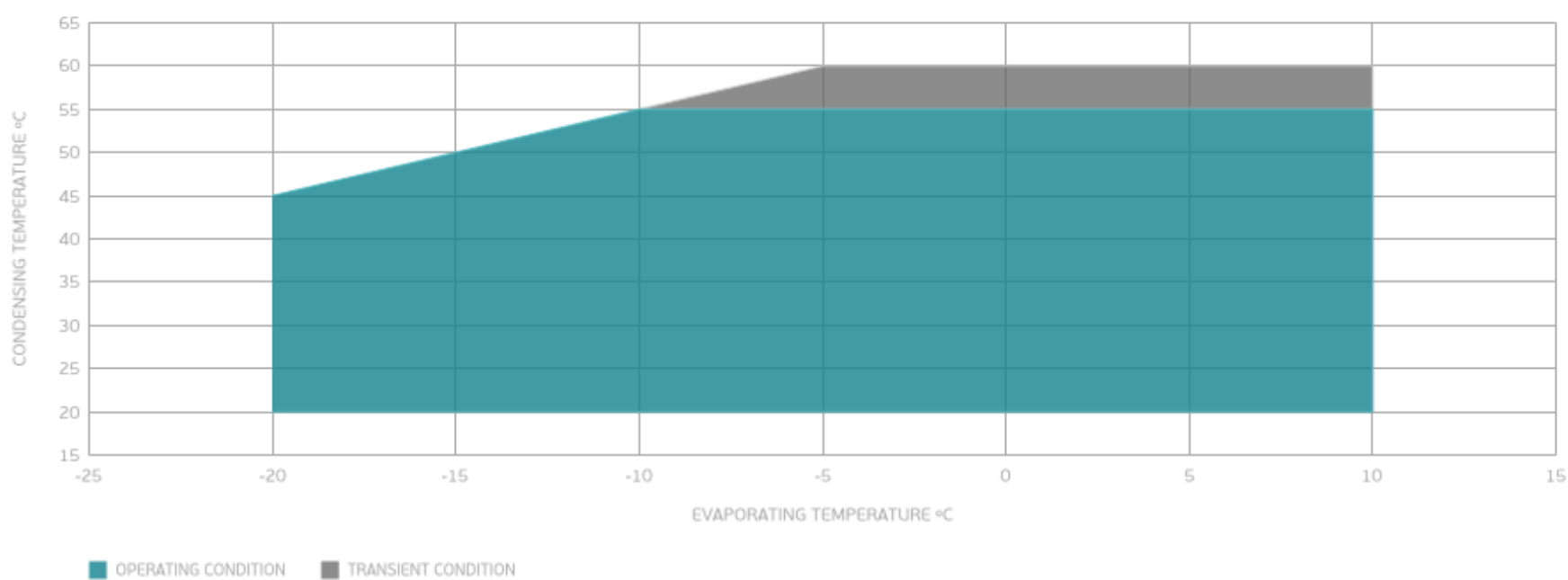

External

EXTERNAL CHARACTERISTICS

Base Plate		SMALL	
Tray Holder		NO	
Connector	Internal Diameter	Shape	Material
Suction	8.1 mm	SLANTED 42°	COPPER
Discharge	6.1 mm	STRAIGHT	COPPER

EXTERNAL DIMENSIONS

SHELL

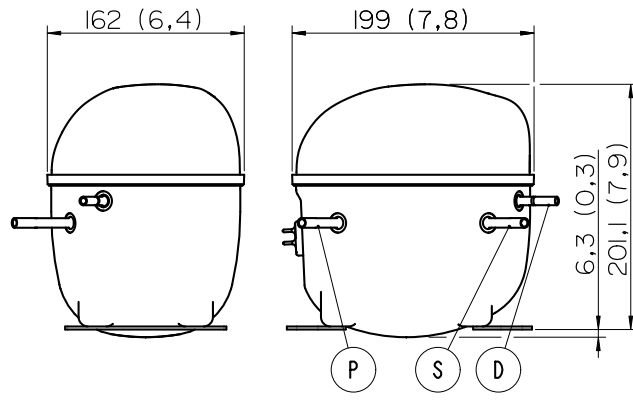

BASE



FENCE

