

SCHEMATIC

BLUEDIAMOND
CONDENSATE REMOVAL PUMPS

BRAND: 

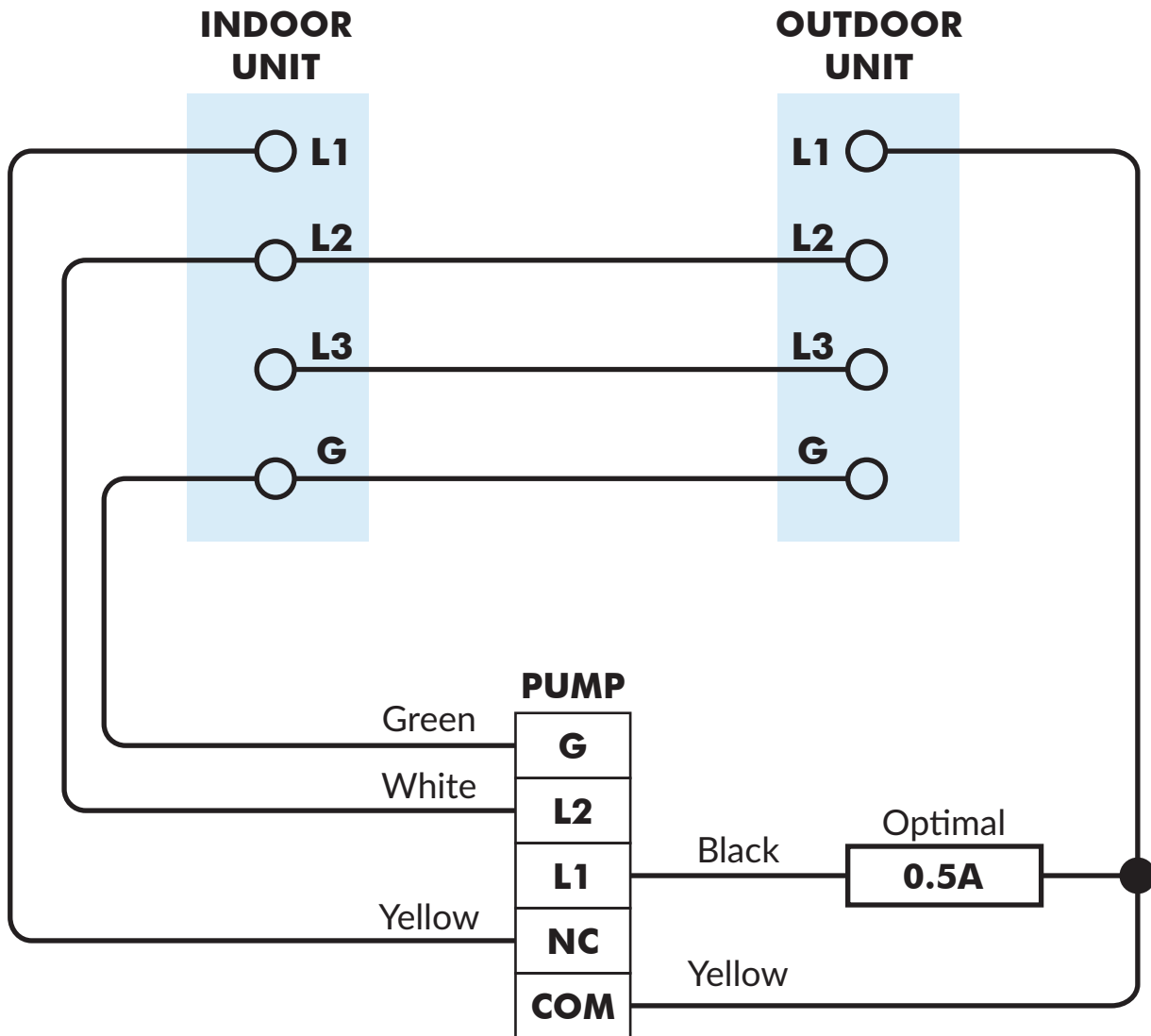

This schematic is provided for general information only and does not constitute a warranty or guarantee of performance. The circuit must be constructed and operated in accordance with the manufacturer's specifications and applicable local regulations. Use of the schematic outside its intended design parameters (e.g., voltage, current, component ratings, or environmental conditions) may result in malfunction or damage and will void any applicable warranty. It is the responsibility of the designer, installer, and end-user to ensure suitability for the intended application.

CARRIER SCHEMATIC

 **CHARLES AUSTEN PUMPS LTD** (Manufacturer)

Address: 100 Royston Road, Byfleet, Surrey, KT14 7NY, United Kingdom
Tel: +44 (0)1932 355277
Email: info@charlesausten.com
Web: charlesausten.com



Global Offices

US Office: Buford, Georgia
UK Office (HQ): Surrey, England
EU Office: Rotterdam, Netherlands

BLUEDIAMOND | bluediamondpump.com

